

SifWELD®



www.sifweld.com

Peters House
The Orbital Centre
Icknield Way
Letchworth Garden City
Hertfordshire
SG6 1ET

Tel. +44 (0) 345 130 7757



SifWeld Evolution CUT40 Air

CE
Approved

PLASMA



Operation Manual



TSXE1P40C

DECLARATION OF CONFORMITY

The Low voltage Directive 2006/95/EC of 12 December 2006, entering into force 16 January 2007
The EMC Directive 2004/108/EC, entering into force 20 July 2007
The RoSH Directive 2011/65/EC, entering into force 2 January 2013

Type of Equipment

Plasma Cutter

Brand name or trade mark

SifWeld® Evolution

Type designation etc.

TSXE1P40C

Manufacturer or his authorised representative established within the EEA**Name, address, telephone no, fax no**

Weldability Sif
Peters House, The Orbital Centre
Icknield Way, Letchworth
Hertfordshire, SG6 1ET
United Kindom
Phone: +44 (0)845 130 7757 Fax: +44 (0)1462 600060

The following harmonised standard in force with the EEA has been used in the design:

EN60974-1- Arc welding equipment- Part 1: Welding power sources
EN60974-10 Arc welding equipment - Part 10: Electromagnetic Compatibility (EMC) requirements

Additional information: restrictive use, Class A equipment, intended for use in locations other than residential

By signing this document, the undersigned declares as manufacturer, or the manufacturer's authorised representative established within the EEA, that the equipment in question complies with the safety requirements stated above.

Place and Date
Letchworth, UK
01-04-2015

Signature



Keith Mullan

Position
Quality Manager
Weldability Sif

WEEE Directive & Product Disposal

At the end of its serviceable life, this product should not be treated as household or general waste. It should be handed over to the applicable collection point for the recycling of electrical and electronic equipment, or returned to the supplier for disposal.



Safety Guidelines

These general safety norms cover both arc welding machines and plasma cutting machines unless otherwise noted. The equipment must only be used for the purpose it was designed for. Using it in any other way could result in damage or injury and in breach of the safety rules. Only suitably trained and competent persons should use the equipment. Operators should respect the safety of other persons.

Prevention against electric shock

The equipment should be installed by a qualified person and in accordance with current standards in operation. It is the user's responsibility to ensure that the equipment is connected to a suitable power supply. Consult with your utility supplier if required. If earth grounding of the work piece is required, ground it directly with a separate cable. Do not use the equipment with the covers removed. Do not touch live electrical parts or parts which are electrically charged. Turn off all equipment when not in use. Cables (both primary supply and welding) should be regularly checked for damage and overheating. Do not use worn, damaged, under sized or poorly jointed cables. Ensure that you wear the correct protective clothing, gloves, head and eye protection. Insulate yourself from work and ground using dry insulating mats or covers big enough to prevent any physical contact with the work ground. Never touch the electrode if you are in contact with the work ground, or another electrode from a different machine. Do not wrap cables over your body. Ensure that you take additional safety precautions when you are welding in electrically hazardous conditions such as damp environments, wearing wet clothing, and metal structures. Try to avoid welding in cramped or restricted positions. Ensure that the equipment is well maintained. Repair or replace damaged or defective parts immediately. Carry out any regular maintenance in accordance with the manufacturer's instructions.

Safety against fumes and welding gases

Locate the equipment in a well-ventilated position. Keep your head out of the fumes. Do not breathe the fumes. Ensure the welding zone is in a well-ventilated area. If this is not possible provision should be made for suitable fume extraction. If ventilation is poor, wear an approved respirator. Read and understand the Material Safety Data Sheets (MSDS's) and the manufacturer's instructions for metals, consumable, coatings, cleaners, and de-greasers. Do not weld in locations near any de-greasing, cleaning, or spraying operations. Be aware that heat and rays of the arc can react with vapours to form highly toxic and irritating gases. Do not weld on coated metals, unless the coating is removed from the weld area, the area is well ventilated, and while wearing an air-supplied respirator. The coatings on many metals can give off toxic fumes if welded.

Prevention against burns and radiation

Arc rays from the welding process produce intense, visible and invisible (ultraviolet and infrared) rays that can burn eyes and skin. Wear an approved welding helmet fitted with a proper shade of filter lens to protect your face and eyes when welding or watching. Wear approved safety glasses with side shields under your helmet. Never use broken or faulty welding helmets. Always ensure there are adequate protective screens or barriers to protect others from flash, glare and sparks from the welding area. Ensure that there are adequate warnings that welding or cutting is taking place.

Wear suitable protective flame resistant clothing. The sparks and spatter from welding, hot work pieces, and hot equipment can cause fires and burns. Welding on closed containers, such as tanks, drums, or pipes, can cause them to explode. Accidental contact of electrode to metal objects can cause arcs, explosion, overheating, or fire. Check and be sure the area is safe and clear of inflammable material before carrying out any welding.

Protection against noise

Some welding and cutting operations may produce noise. Wear safety ear protection to protect your hearing.

Protection from moving parts

When the machine is in operation, keep away from moving parts such as motors and fans. Moving parts, such as the fan, may cut fingers and hands and snag garments. Protections and coverings may be removed for maintenance and controls only by qualified personnel, after first disconnecting the power supply cable. Replace the coverings and protections and close all doors when the intervention is finished, and before starting the equipment. Take care to avoid getting fingers trapped when loading and feeding wire during set up and operation. When feeding wire be careful to avoid pointing it at other people or toward your body. Always ensure machine covers and protective devices are in operation.

Precautions against fire and explosion

Avoid causing fires due to sparks and hot waste or molten metal. Ensure that appropriate fire safety devices are available near the cutting / welding area. Remove all flammable and combustible materials from the cutting / welding zone and surrounding areas. Do not cut/weld fuel and lubricant containers, even if empty. These must be carefully cleaned before they can be cut/welded. Always allow the cut/welded material to cool before touching it or placing it in contact with combustible or flammable material. Do not work in atmospheres with high concentrations of combustible fumes, flammable gases and dust. Always check the work area half an hour after cutting to make sure that no fires have begun.

Risks due to magnetic fields

The magnetic fields created by high currents may affect the operation of pacemakers or electronically controlled medical equipment. Wearers of vital electronic equipment should consult their physician before beginning any arc welding, cutting, gouging or spot welding operations. Do not go near welding equipment with any sensitive electronic equipment as the magnetic fields may cause damage.

RF Declaration

Equipment that complies with directive 2004/108/EC concerning electromagnetic compatibility (EMC) and the technical requirements of EN60974-10 is designed for use in industrial buildings and not those for domestic use where electricity is provided via the low voltage public distribution system. Difficulties may arise in assuring class A electromagnetic compatibility for systems installed in domestic locations due to conducted and radiated emissions. In the case of electromagnetic problems, it is the responsibility of the user to resolve the situation. It may be necessary to shield the equipment and fit suitable filters on the mains supply.

LF Declaration

Consult the data plate on the equipment for the power supply requirements. Due to the elevated absorbcency of the primary current from the power supply network, high power systems affect the quality of power provided by the network. Consequently, connection restrictions or maximum impedance requirements permitted by the network at the public network connection point must be applied to these systems. In this case the installer or the user is responsible for ensuring the equipment can be connected, consulting the electricity provider if necessary.

Materials and their disposal

The equipment is manufactured with materials, which do not contain any toxic or poisonous materials dangerous to the operator. When the equipment is scrapped, it should be dismantled separating components according to the type of materials. Do not dispose of the equipment with normal waste. The European Directive 2002/96/EC on Waste Electrical and Electronic Equipment states the electrical equipment that has reached its end of life must be collected separately and returned to an environmentally compatible recycling facility.

Handling of Compressed gas cylinders and regulators

All cylinders and pressure regulators used in welding operations should be handled with care. Never allow the electrode, electrode holder or any other electrically "hot" parts to touch a cylinder. Keep your head and face away from the cylinder valve outlet when opening the cylinder valve. Always secure the cylinder safely. Never deface or alter any cylinder.



The following signs and explanations are to remind the user of the potential risks involved and the dangers of misuse or mistreatment of the welding machine.



RUNNING PARTS MAY BE DANGEROUS!

Keep away from running components, including the fan.



ELECTRIC SHOCKS CAN KILL!

Never touch electrical parts. Keep the equipment in good condition, replace damaged parts, undertake regular maintenance according to the instructions.



BE AWARE OF SPARKS AND SPATTER

Wear protective clothing, such as leather gloves, Flame retardant overalls, boots and eyewear.



DO NOT TOUCH THERMAL COMPONENTS!

Thermal components may cause severe burns when in contact with unprotected skin.

Contents

1.	Preface	7
1.1	General	7
1.2	Introduction	8
1.3	Technical Specifications	9
1.4	Overview of Machine	10
2.	Control Panels	11
2.1	Display Instruction	12
2.2	Further Controls	13
2.3	Air Check Display	14
3.	Installation	15
3.1	Air Connections	15
4.	Operation	16
4.1	Cutting Operation	16
5.	Troubleshooting	17
6.	Maintenance	18
7.	Warranty	19

1. Preface

1.1 General

Congratulations on choosing your SifWeld Evolution TSXE1P40C Plasma Cutter.

Used correctly, SifWeld products can significantly increase the productivity and provide years of economical service. This operating manual contains important information on the use, maintenance and safety of your SifWeld product. Please read the manual carefully before using the equipment for the first time. For your own safety and that of your working environment, pay particular attention to the safety instructions in the manual.

For more information on SifWeld products, consult an authorised SifWeld dealer, or visit the SifWeld web site at www.sifweld.com. The specifications presented in this manual are subject to change without prior notice.

Important notes

Items in the manual that require particular attention in order to minimise damage and personal harm are indicated with the **'NOTE!'** notation. Read these sections carefully and follow their instructions.

Disclaimer

While every effort has been made to ensure that the information contained in this guide is accurate and complete, no liability can be accepted for any errors or omissions. We reserve the right to change the specification of the product described at any time without prior notice. Do not copy, record, reproduce or transmit the contents of this guide without prior permission.

1.2 Introduction

The SifWeld Cut40 AIR professional 40Amp plasma with Built In Compressor is designed for hand-held efficient cutting in manufacturing, sheet metal, general maintenance industries and automotive.

The Built In Compressor gives the operator the advantage of Plasma Cutting when an external Air Supply is not available, just flip the switch and the machine can be used with external air supply in the workshop. The SifWeld Cut40 AIR can be used to efficiently cut mild and low alloy steels, stainless, aluminium, copper, titanium and nickel alloys.

Features

- CUT40 Air
- 40A, 230V single phase plasma cutter
- Very high duty cycle, 100% at 30A
- Used with internal compressor or external air supply
- Full digital control with LCD display for showing the output, monitoring and displaying any torch or machine faults.
- Max cutting thickness 20mm, severance on carbon steel, external air
- 18mm thickness with built in compressor
- Quick connect plasma Eurotorch Connector
- 6M manual plasma cutting torch included.

1.3 Technical Specifications

SifWeldEvolution CUT40 AIR		
Rated Input Voltage (V)		1-230±10%
Frequency (HZ)		50/60
Rated Input current (A)		28.2
Rated Input Power (KW)		6.5
Cutting Current Adjustment Range (A)		20~40
No Load Voltage (V)		393
Duty Cycle (40°C 10 minutes)		20% 40A
		100% 30A External Air
Severance Cut for Carbon Steel (mm)		≤ 25
	Carbon steel	≤ 20
Optimal Cutting	Stainless steel	≤ 20
Thickness (mm)	Aluminum	≤ 10
	Cuprum	≤ 12
Dimensions (mm)		510 x 146 x 278
Protection Class		IP21S
Circuit Breaker		D32A
Weight (Kg)		18.9
Cooling Method		AF

1.4 Overview of Machine

Front View

Power Source Front Panel Layout

1. Cutting gun connector
2. Positive output cable

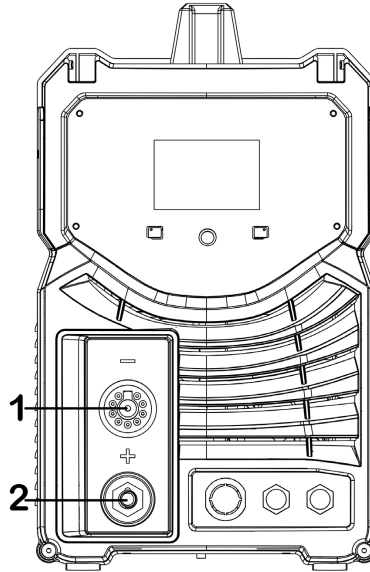

Rear View

3. Power cable
4. Power switch
5. Air pump switch
6. Air pressure regulator (not fitted on this model)
External air inlet is fitted in this position instead

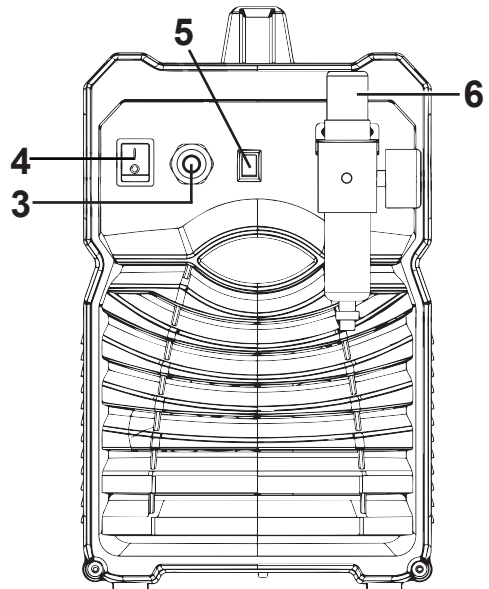

2. Control Panels

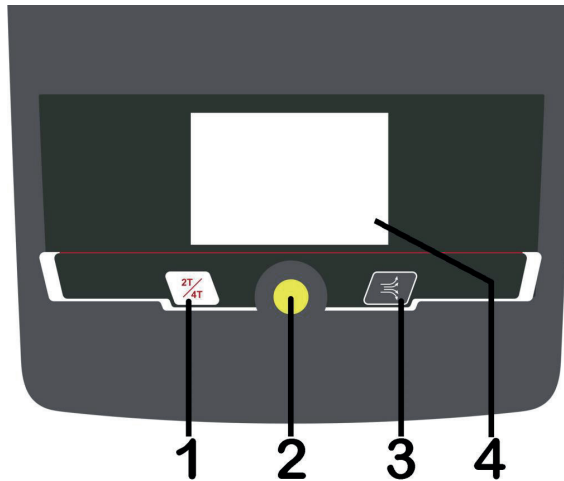

1. Trigger mode button

Press the button to select 2T or 4T trigger mode.

2. Cutting current knob

Counterclockwise rotation reduces the current and clockwise rotation increases the current.

3. Air check button

Press the button, if the machine is not connected to the gas line or the air pressure is low, the screen will display "Undervoltage".

4. Screen

It displays cutting current, trigger mode and error codes.

2.1 Display Introduction

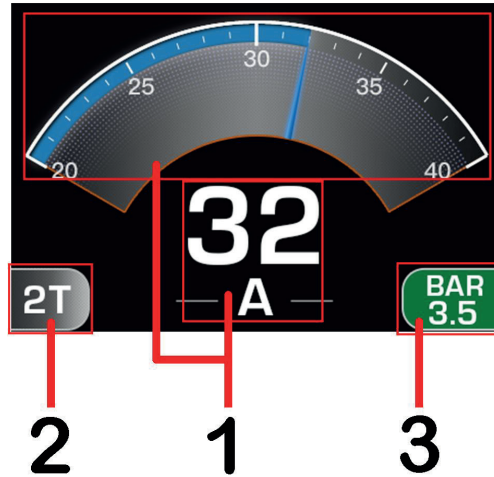

1. Current display

This is current display. Adjust it by the knob. Unit: A. the range of adjustment is 20~40A.

2. Trigger mode display

This will display 2T or 4T trigger mode.

3. Air check display

This will display air pressure, otherwise "Undervoltage" will be displayed.*

2.2 Further Controls Explained

TRIGGER MODE DISPLAY

- When 2T operation is selected, pressing trigger starts air, touch and lift arc to start. Release trigger to stop air and arc.

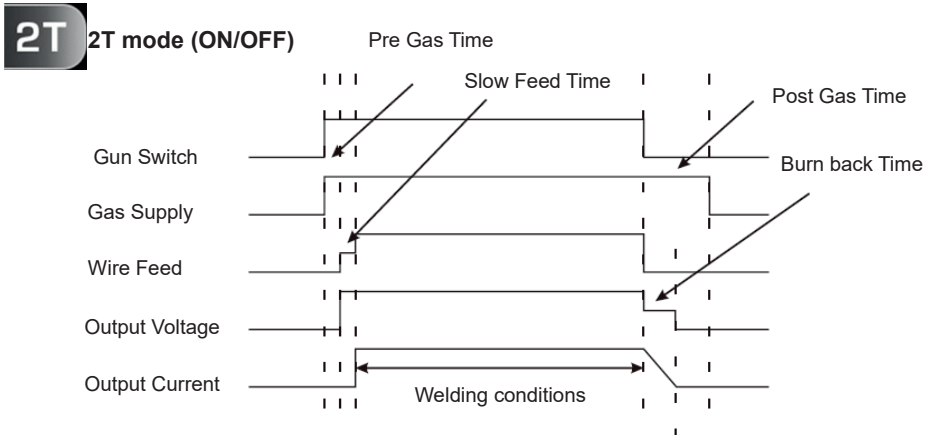

- When 4T operation is selected, press and release trigger to start air, touch and lift arc to start. Press and release trigger again to stop air and arc.

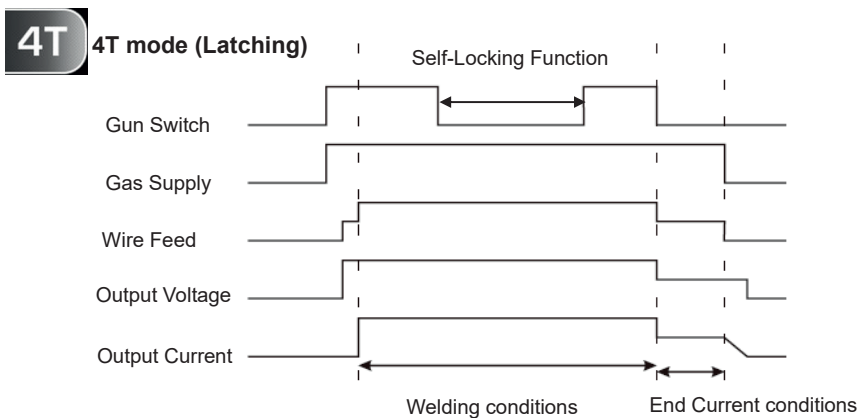

2.3 Air Check Display

Press the air check button to check whether the air passage is smooth. If the machine is working properly, the screen will display the air pressure value normally, as shown in the figure below:



If the machine is not ventilated or the air path is not smooth and the air pressure is too low, it will cause the machine to alarm and display "E12 Undervoltage", as shown in the figure below:

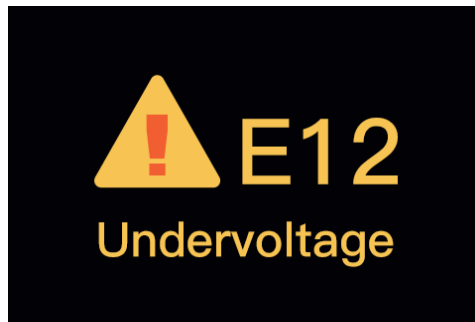

3. Installation

Unpacking

Check the packaging for any signs of damage. Carefully remove the machine and retain the packaging until the installation is complete.

Location

The machine should be located in a suitable position and environment. Care should be taken to avoid moisture, dust, steam, oil or corrosive gases. Place on a secure level surface and ensure that there is adequate clearance around the machine to ensure natural airflow.

Input connection

Before connecting the machine you should ensure that the correct supply is available. Details of the machine requirements can be found on the rating plate of the machine or in the technical parameters shown in the manual. The equipment should be connected by a suitably qualified competent person. Always ensure the equipment has a proper grounding. Never connect the machine to the mains supply with the panels removed.

If the power supply voltage continually goes beyond the range of safe work voltage range, it will shorten the welder life-span. The following measures can be used:

- Change the power supply input.
- Reduce the machines power supply that it is using at the same time;
- * Set the voltage stabilization device at the front of power cable input.

3.1 Air Connections

1. Select air inlet mod

You can choose to compress the air through the air pump or through the external oil-water separator on the rear panel.

2. Connecting air supply to unit

If external connection is selected, please connect the gas line to the external oil-water separator on the rear panel.

3. Check Air Quality

To test the quality of air, press down the air check button, check if there are any oil or moisture in the air.

NOTE! Air should be free from moisture, oil or large capital damage may occur to the machine/torch and your guarantee could be void.

4. Operation

Before starting any welding activity ensure that you have suitable eye protection and protective clothing. Also take the necessary steps to protect any persons within the area.

Cutting Preparation

1. Tightly connect the power cable to electrical socket outlet (the input voltage, refer to the section 2 technology parameters).
2. To connect the air line to the air supply equipment, the earth cable to the workpiece.
3. Turn on the power switch, the power indicator on.
4. Regulate the air pressure to 3.5~6 bar external air.
5. Regulate the current after the flow stops as your requirement.
6. Now all the preparation done.

4.1 Cutting Operation

1. NORMAL CUT

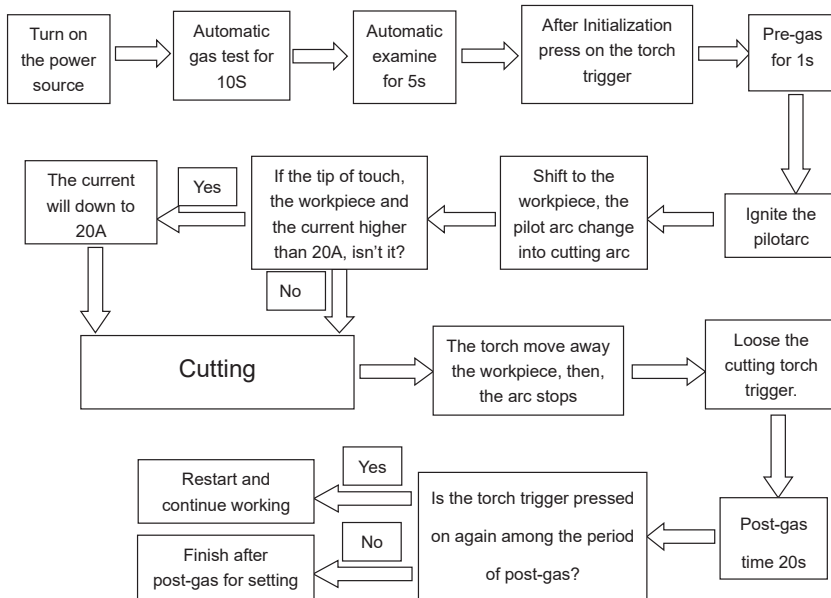

5. Troubleshooting

Note

1. If the alarm appears on the screen when cutting, it is needed to loose the switch of the gun until the alarm release, then press on the switch to restart working.
2. In the automatic air test and examine, press on the cutting gun, there will no reflection.
3. After a long usage, the surface of the electrode and nozzle will have oxidation reaction. Please replace the electrode and nozzle, For The alarm indicator will on when install the shield cup, and stop working
4. Among the period of post air, if you press the trigger for a long time, the arc restart; if you press and loosen the trigger quickly, the air stops, after it you can press the trigger for a long time to restart the machine as well.

2. ACCOUNT FOR THE ALARM INDICATOR

1. When the machine appears over-heat, the screen will display error code "E01 Overheat".

Overheat: The alarm will release after the period of fan cooling. You can restart the machine.



2. When the air pressure is too lower, the screen will display error code E12 Undervoltage



3. When the gas distributor is un installed only, there is not alarm while operating the machine, and when you press the trigger, there is no arc and no load as well. Open the torch and check it.

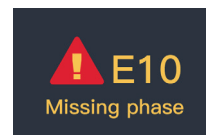

4. The product uses three phase input voltage. If the input voltage is short of phase, the machine will not work properly, and the following alarm will appear.

6. Maintenance

The utilisation level of the power source and its working environment should be taken into consideration in planning the frequency of maintenance of the machine. Appropriate use and preventive maintenance guarantee the best trouble-free use of the equipment. This allows you to avoid interruptions in use and increases the productivity of the machine.

5.1 Cables

Check the condition of welding and mains cables daily. Do not use damaged cables. Also make sure that all extension cables used in the mains connection are in proper condition and compliant with regulations.

NOTE! The mains cables may be repaired and installed only by electrical contractors and installers authorised to perform such operations.

5.2 Power source

Make sure the machine is placed away from any grinding area.

1. Clean the exterior of the machine and the fan grills net of any dust and stains – for example, with a soft brush and vacuum cleaner.
 - Do not use pressurised air. The stain may become compressed into the grooves of the coolers.
 - Do not use a pressure-washing device.
2. Check the electrical connections of the machine. Clean any oxidised connections, and tighten the loosened ones.
 - Check for the right tension before you start repairing the connections.

NOTE! Remember that the machine may be repaired only by an electrical contractor or installer authorised to perform such operations.

5.3 Regular maintenance

Authorised service agents perform regular maintenance by agreement. Tasks included in regular maintenance:

- Cleaning of equipment.
- Inspection and maintenance of the welding gun.
- Checking of connectors, switches, and control knobs.
- Checking of electrical connections.
- Checking of the mains cable and plug.
- Replacement of damaged or worn parts.
- Calibration testing, with adjustment of the functions and operational values of the machine, if necessary.

7. Warranty

Weldability Sif warrants its customers that all new SifWeld manual welding and cutting equipment purchased shall be free of failure from defective materials or production for a period of 2 Years from the date of purchase.

This warranty period can be extended to 5 Years from the date of purchase (including the standard warranty period) for customers in the United Kingdom and Republic Of Ireland; or to 3 Years from date of purchase for customers in all other countries, subject to registration of the product at www.sifweld.com within the first year of purchase, and undergoing annual preventative maintenance servicing with effect from the second year of ownership.

All warranty periods start from the date of purchase from Weldability Sif or an approved SifWeld distributor to the original end user. The date on the sales invoice is considered the date of purchase for the purpose of the warranty period, or the date of manufacture is used if proof of purchase is not available. Equipment is warranted to the original owner/user customer, and is not transferable.

Subject to the underlying purchase contract, or, failing such, the Weldability Sif general terms and conditions of sale, both the cost of replacement parts and Weldability Sif's labour expense in correcting defects covered by the warranty, will be assumed by Weldability Sif during the warranty period. Weldability Sif shall in no event be responsible for any direct or indirect damages, third party expenses, as well as any loss of income/revenue, all of which are specifically excluded under this warranty.

The warranty does not cover : Any defects resulting from normal wear and tear; Improper use; Failure to observe the operating and maintenance instructions; Connection to an incorrect or faulty mains supply; Overloading during use; Any transport or storage damage; External damage such as fire, impact or damage due to natural causes, e.g flooding; Use of unapproved spare or wear parts or replacement parts not supplied by or approved by Weldability Sif; Any modification or alteration of the equipment; or any other circumstances beyond the control of Weldability Sif. The warranty period is based on a single 8-hour 5-day shift pattern and the extended warranty is not applicable to units that are purchased for rental or hire. Weldability Sif will submit an invoice for any repair work performed outside the scope of the warranty.

Any warranty repair must be performed by Weldability Sif or an Authorised SifWeld Service Centre. The customer is responsible for all shipping costs and risk associated with items that are returned covered under warranty. Weldability Sif may opt to refund the purchase price (less any costs and depreciation due to use and wear). Faults/defects found under warranty should be reported to the Weldability Sif Technical team for review. A warranty claim reference number will be issued and details of the most appropriate Authorised SifWeld Service Centre will be advised, if appropriate. The customer has no claim to any loan or replacement products whilst repairs are being performed or replacements are being provided.

The decision about repair or replacement of any defective part(s) is made by Weldability Sif. The replaced part(s) remain(s) property of Weldability Sif. The warranty extends only to the machine power-source, wire-feed unit and parts contained inside. No other warranty is expressed or implied, including with regard to the fitness of the equipment for any particular application.

Under the terms of the warranty, welding torches, their consumable parts, wire-feed drive-rolls and guide tubes, work return cables and clamps, electrode holders, connection and extension cables, mains and control leads, plugs, wheels, coolant, etc. are not covered.

The extended warranty is only valid where products have been used strictly in accordance with the operating instructions, all installation guidelines have been implemented, all legal requirements have been observed, regular preventative maintenance has been undertaken and a continuous history of annual servicing has been completed and recorded. Failure to register the equipment online within 1 year of purchase, or to complete the required annual servicing cycle from year 2, will invalidate the extended warranty period.

Annual preventative maintenance servicing must be arranged and paid-for by the equipment owner/user and carried out by Weldability Sif or an Authorised SifWeld Service Centre, in order to maintain validity of the extended warranty. Service visits can be booked online at www.sifweld.com or by calling 0870 330 7757 and will be charged at an average of £65 net per hour of travel/ servicing time. Please allow an average of 2 hours servicing per machine and one hour each way of travel.

Warranty support is facilitated by our network of Authorised SifWeld Service Centres that provide highly experienced capability and carry-out the professional repair, service and calibration of SifWeld equipment.



Weldability sif

Peters House, The Orbital Centre, Icknield Way, Letchworth Garden City, Hertfordshire, SG6 1ET
Tel. +44 (0) 345 130 7757 | Fax. +44 (0)1462 600060 | Email. sales@weldability-sif.com | www.sifweld.com